



MÄRKISCHES WERK
Your Engine. Our Ingenuity.™

Märkisches Werk GmbH

Haus Heide 21
58553 Halver, Germany
Phone: + 49 - 2353 - 917 - 0
Email: info@mwh.de

MWH Americas
americas@mwh.de

MWH China
china@mwh.de

MWH Japan
japan@mwh.de

MWH Singapore
singapore@mwh.de

MWH ReliaValve with Sentry Rotator

An Innovative and Patented Mechanical Valve Rotator for 2-Stroke Engines.

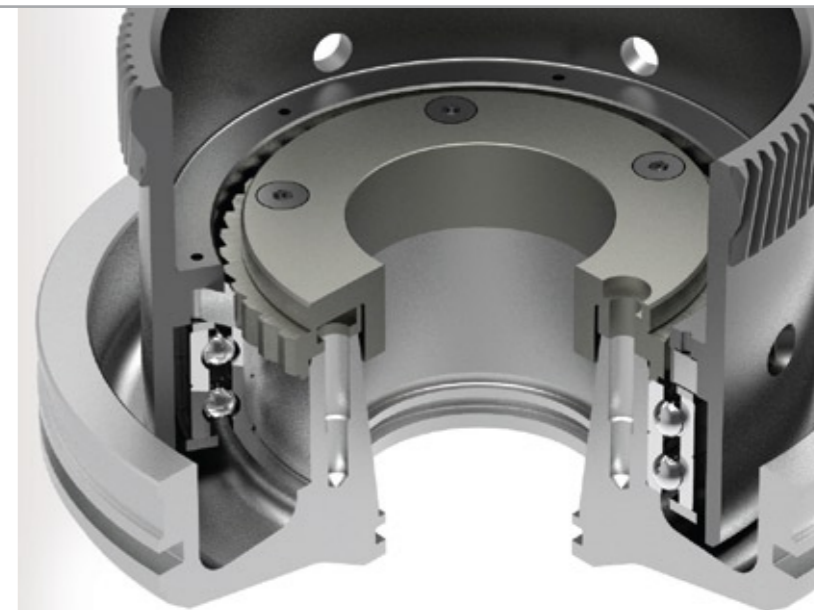

MÄRKISCHES WERK
Your Engine. Our Ingenuity.™



INTRODUCTION

Two-stroke engine exhaust valves operate under extremely harsh thermal and environmental conditions that typically result in a 6,000 - 8,000 hr. service interval for these components [1]. Exposure to high temperatures and heavy fuel oil (HFO) combustion products can lead to severe chemical attack on the valve head and other parts of the exhaust system. Eco-speed and low steaming can reduce engine speeds down to 10% load. Combined with the additional low sulphur requirements, these conditions can promote rapid wear of the valve spindle seat surface. MWH has seen by-products of the combustion with ashes of non-burning constituents coming from the HFO as well as from the lubeoil.

This paper describes the design, testing and serial operation of a novel mechanical valve rotator for increasing the service life of 2-stroke engine exhaust valves.

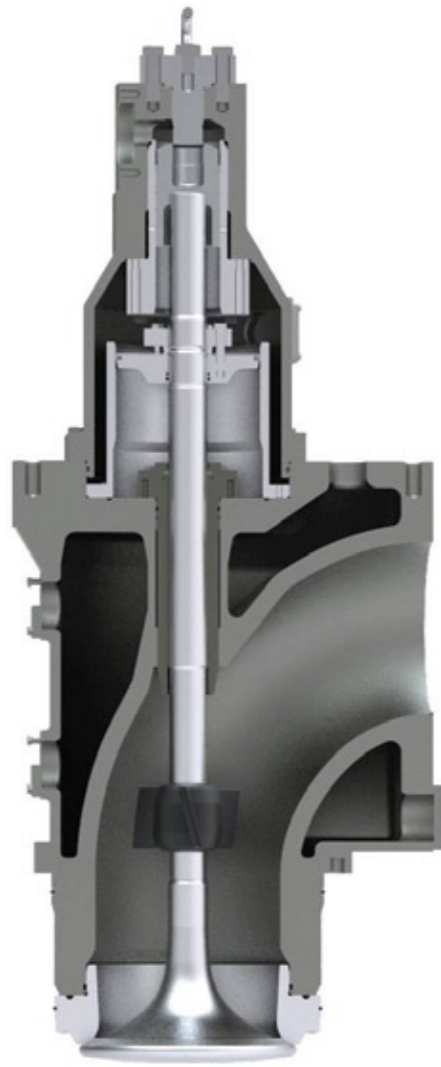

Figure 1: Typical 2-stroke engine exhaust valve

DESIGN OF CURRENT EXHAUST VALVES AND WEAR MECHANISMS

A large fraction of the world's marine 2-stroke engines are designed by three manufacturers: MAN-B&W (MC-Series), Wärtsiläe-Sulzer (RTA-series) and Mitsubishi (UEC-series). Each engine design has unique features, but many general characteristics of the exhaust system are common to all three manufacturers. Figure 1 shows a typical 2-stroke exhaust valve assembly, including the valve drive (hydraulic actuator), pneumatic spring (air cylinder), valve housing, valve guide, valve spindle (with vane rotator), and bottom piece or valve seat.

Wear Mechanisms in 2-stroke Engine Exhaust Valves

The most prevalent wear mechanisms in 2-stroke engine valves have been described in [2] and include:

- Adhesion and abrasive wear
- Macro particles and dent marks
- Build up of glassy-deposits
- Low temperature corrosion
- High temperature corrosion
- Low-cycle fatigue

The first two of these wear mechanisms (adhesion/abrasive wear and macro particles/dent marks) are of particular interest to this project, and are described in further detail.

Adhesion and abrasive wear refers to a mechanism in which deposit particles can become entrapped between the valve guide and valve spindle stem. These particles adhere to the valve spindle guide and cause abrasive wear on guide and stem. This mechanism causes a sticking effect which can prevent rotation of the valve spindle. Lack of rotation causes un-symmetric heating and distortion of the valve spindle head, which can subsequently lead to combustion gas leaks and erosion. Figure 2 shows a photograph of a valve guide with considerable deposit particle adhesion.



Figure 2: Valve guide with evidence of adhesion and abrasive wear [6].

Macro particles and dent marks refers to a mechanism in which particles and deposits formed as a by-product of the combustion of fuel (HFO) become trapped between the valve spindle and seat ring. When the valve spindle closes on the seat ring, these particles generate a 'dent' in each of the paired surfaces. Repeated denting of the seating surfaces can eventually create a path for leakage of combustion gases. Once this occurs, the hot combustion gases lead to the rapid erosion and corrosion of these metal surfaces. Figure 3 shows a photograph of a valve spindle with extensive evidence of dent marks.



Figure 3: Valve spindle with extensive evidence of dent marks [6].

Recently, we have begun to see a new type of wear mechanism on the valve spindle seat, the so called "glassing" or "glassy-deposits". As opposed to the well known wear mechanism from macro-particle indentation (see Figure 3), these glassy-deposits form a thin, hard layer only on the valve spindle seat surface. The mechanism of the glassy deposit formation is very complex and appears to be related to a combination of the following conditions:

- Fuel (HFO) quality
- Lubeoil quality and quantity
- Engine operation condition
- Temperature
- Seating pressure

Engines operating with eco-speed or extreme low-steaming down to 10% load experience high valve spindle temperatures caused by the lower cooling effect of the scavenge air (low scavenge air pressure follows low load). In addition, the specific lubrication quantity under low-load conditions is high. The low sulphur content of the fuel (HFO) results in an over-abundance of calcium from the lubeoil. Under these conditions, the possibility of creating glassy-deposits on the seat area of the valve-spindle becomes high when the correct seat contact pressure is present. Build-up of glassy-deposits on the seat of the bottom piece has not been observed.

These glassy-deposits (see Figure 4) have a hardness of approximately 800 HV with high adhesion to the valve seat material. During inspection, it is only possible to remove the glassy-deposits from the valve spindle seat with hard metal scrapers. Different coefficients of thermal expansion between the valve spindle seat and the glassy-deposits lead to radial cracks in the deposit layer. These cracks are the initiation of exhaust gas channels. After a channel is formed, and a blow through begins to develop, the local temperature increases, accelerating the local corrosion and causing rapid removal of the metal surface itself [3]. Typical so called "cobblestone" corrosion [4], characteristic of high-temperature corrosion is documented in Figure 4 as type of valve spindle wear. Subsequent valve spindle failure usually results.



Figure 4: Valve spindle with extensive "glassy-deposits" and beginning of blow-by.

Analysis of Glassy-Deposits

MWH analysis of the glassy-deposits showed the presence of compounds of calcium, vanadium, sulphur and sodium. Under pressure and temperature, the salts crystallize to form a thin glassy layer. Kingston-Jones, *et al.* have described the formation of low melting point salts in detail [5]. Sulphur oxides (SO₂ and SO₃), vanadium oxides (V₂O₅) and sodium oxides (Na₂O) from the combustion process react with each other and with calcium from the lubeoil to form these low melting



point salts. These salts include sodium sulphate (NaSO₄), calcium sulphate (CaSO₄) and sodium vanadyl vanadates of varying compositions (usually referred to as NaVV). Table 1 shows a list of sodium vanadyl vanadates and their respective melting points.

Table 1: Melting points of some vanadates [5].

Compound	Temperature °C
NaVV* (5:12)	570
NaVV (1:6)	625
NaVO ₃	630
V ₂ O ₅	650-680
MgV ₂ O ₆	680-700
CaV ₂ O ₆ , BaV ₂ O ₆	700-705
NiV ₂ O ₆	720
CaV ₂ O ₆	778
CrVO ₄	810
FeVO ₄	816
Ca ₂ V ₂ O ₇	820
Ba ₂ V ₂ O ₇	863
Ni ₂ V ₂ O ₇	880
Ca ₂ V ₂ O ₇	1015

*NaVV = sodium vanadyl vanadate 5:12 = 5Na₂O.V₂O₄.11V₂O₅
1:6 = Na₂O.V₂O₄.5V₂O₅

Seat Ring Geometry

The three different designs of the seat of the bottom piece of 2-stroke exhaust valves were described extensively in [6]. The standard-type design features flat valve spindle and seat ring surfaces, while the W-type and Chamber-type seat rings employ a more complex geometry with the aim of addressing the dent mark wear mechanism. These seat ring designs generate higher interfacial contact loads, and provide a pocket where cool, un-combusted gases can reside next to the seating surface. If a passage for gas leakage is created by dent marks, the cool gases can escape without eroding the metal surfaces of the valve spindle and seat ring.

Seat ring geometry modifications can be used to alleviate the dent wear mechanism, but the adhesion and abrasive mechanism (sticking of valve spindle stem) and blow-byes (glassy-deposits) must be addressed by other means, see also Figure 4 (chamber-type) and Figure 5 (W-type).



Figure 5: Valve spindle with extensive dentmarks and beginning of blow-byes (W-type geometry of bottom piece).

Conventional Valve Rotation Mechanisms

Rotation of the valve spindle within the exhaust valve assembly is beneficial for several reasons, and it generally reduces the wear rate of the exhaust valve assembly. Today, most 2-stroke exhaust valves rely on aerodynamic vanes (wing bushes) for passive spindle rotation (see Figure 1). Exhaust gases flow over the vanes and rotate the spindle as it opens, creating an axi-symmetric temperature distribution, and reducing thermal gradients within the valve spindle. This decreases distortion and thermal stresses within the spindle, and reduces low and high cycle fatigue. However, in some types of engines, vanes fail to provide additional important benefits, namely the polishing and removal of residuals on the valve spindle sealings surface and overcoming the stiction caused by deposits within the valve guide. As discussed previously, these phenomena lead to wear of the exhaust spindle, guide and seat ring, and ultimately force most operators to service their exhaust valves after 6,000 to 8,000 hours of service. The rotation rate of the spindles is not controlled with the use of aerodynamic vanes. As a result, inadequate rotation is achieved at low engine speeds and loads, and insufficient rotational torque is generated to overcome stiction within the valve guide once adhesion and abrasive wear are initiated. Positive mechanical rotation addresses the shortcomings of traditional valve rotators.



DESIGN FEATURES OF THE MECHANICAL VALVE ROTATOR

Various approaches for controlling wear in exhaust valves have been employed with various degrees of success. This paper describes the design of a mechanical valve rotator that addresses both of the aforementioned wear mechanisms to extend the service interval of 2-stroke exhaust valves.

The main benefit of mechanical rotation is achieved when a certain wiping or grinding effect is produced on the valve spindle and seat ring surfaces. This seating surface polishing effect is produced by the valve spindle's rotational motion as it contacts the bottom piece or seat ring [5].

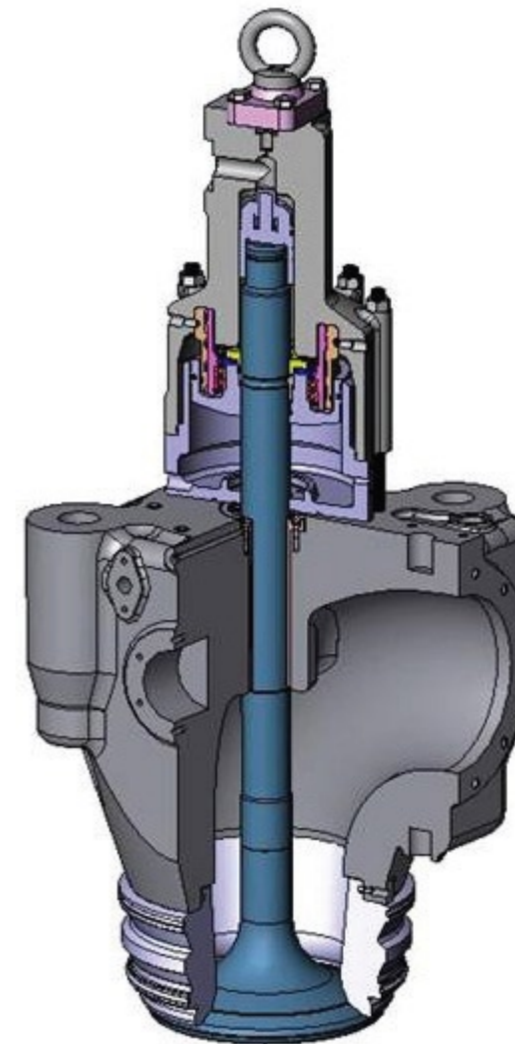

Figure 6: Exhaust valve assembly with mechanical valve rotator.

An innovative and patented mechanical valve rotator (Sentry Rotator) for 2-stroke engines has been developed by Märkisches Werk GmbH (MWH). This valve rotator mechanism can be incorporated into an existing exhaust valve assembly with only minor modification, as shown in Figure 6 and Figure 7. The rotator features an inner and outer drive element. The helical rotating gear is linked to the inner drive element via a free-wheel device that transmits a rotation to the valve stem during the valve closing movement. The helical gear rotator and free-wheel mechanism are shown in Figure 8.

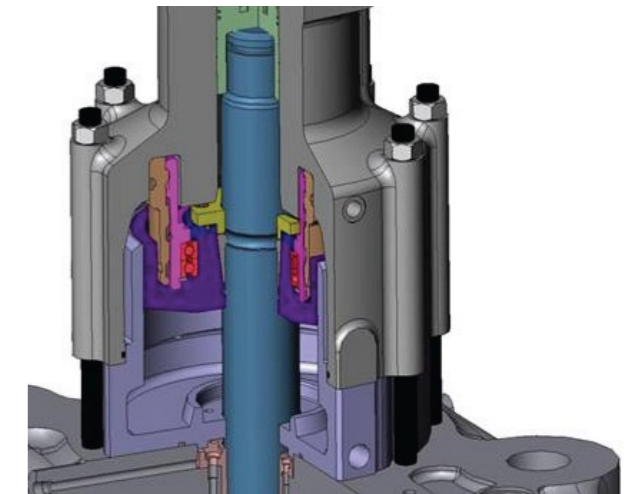

Figure 7: Detail view of mechanical valve rotator mechanism.



Figure 8: Helical gear rotator and free-wheel mechanism.



Advantages of Mechanical Rotation

The mechanical valve rotator essentially forces a controlled rotation of the valve spindle during the valve closing movement. This continuous rotation speed can be tuned from 3 – 20 rpm, and is a linear function of the engine speed. In addition, this valve rotation is achieved even under conditions where sticking in the valve guide would prevent rotation with an aerodynamic vane.

The Sentry Rotator provides all the traditional benefits of valve rotation, including an axis-symmetrical temperature distribution in the valve spindle to reduce thermal stresses and improve low and high cycle fatigue life. However, by rotating the valve spindle during the closing movement, a continuous polishing effect is achieved on the seating surfaces of the valve spindle and bottom piece. This seat polishing effect prevents deterioration by dent marks and dramatically reduces the possibility of combustion gas leaks. In essence, continuously polishing the seating surfaces ensures that all functions of the seat (gas sealing, heat transfer, etc.) remain at peak efficiency throughout the life of the engine.

An additional possible benefit is that, by removing the aerodynamic vane (wing bush) from the valve spindle stem, an improvement in scavenging efficiency may be achieved. This could result in improved thermodynamic efficiency of the engine and reduced fuel consumption. However, this effect has not yet been quantified.

Mechanical valve rotation addresses two of the major mechanisms for exhaust valve wear (adhesion and abrasive wear and build up of deposits and dent marks) which enables an increase in time between overhauls of exhaust valve assemblies.

FIELD TESTS AND SERIES OPERATION

First MWH ReliaValve reached 37,505 hours operating experience

Various engine field tests have been in progress since 2003, on several engine types and sizes. The results of the first four years were documented in [6]. One such field test was performed on the "MV Libra Buenos Aires / CMA CGM Bahia", which is powered with a MAN-B&W 7L70MC engine (see Figure 9). A new Nimonic exhaust valve and Sentry Rotator were installed in 2003 in cylinder # 1 of this engine. As reported in 2007 [6], the ReliaValve had successfully reached 16,647 hours of operation. Periodic inspections at 1,000, 4,200, 9,100, and 16,647 hours of the general function of the ReliaValve and, in particular, the seating

surfaces on the valve spindle and bottom piece were performed. In 2007, the inspection showed that the continuous rotation described above was effective in maintaining clean, polished seating surfaces. Moreover, no dent marks were visible on either the valve spindle or bottom piece surfaces. Even after 16,647 hours of operation, there was no evidence of excessive wear on the seating surfaces.

Based on the positive results seen in 2007, the target of 30,000 hours service-free operation was deemed as possible. Additional to the on-going field test on six MAN-B&W engines in the range from MC60 to MC90 type, there are also nine MAN-B&W engines completely equipped with converted ReliaValves. With this wide range of experience, the MWH ReliaValves have been approved for 30,000 hours or more. The only scheduled maintenance item for the ReliaValve with Sentry Rotator consists of the replacing the valve spindle stem seals after 15,000 to 18,000 hours. This work can be performed on board without removing the complete ReliaValve from the engine. Only disassembly of the valve drive and air cylinder is necessary to change the stem sealings. It is recommended that the free-wheel mechanism and axial bearings of the Sentry Rotator be inspected every 30,000 hours and replaced, if necessary.

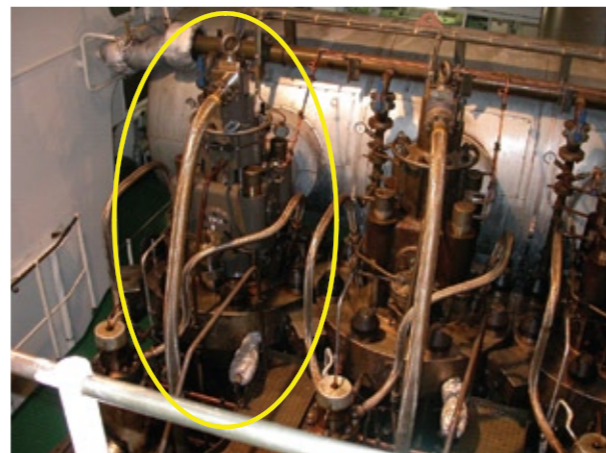

Figure 9: Cylinder #1 of the MAN-B&W 7L70MC engine on the "MV Libra Buenos Aires / CMA CGM Bahia" [6].

Figure 10 through Figure 17 show the inspection results and the reliability of the first ReliaValve on the "MV Libra Buenos Aires / CMA CGM Bahia". These pictures document the operation up to the 37,505 hour inspection performed in January 2010. The helix gear and the ratchet system were last inspected at 31,882 hours. These components appeared in as-new condition with no visible wear.



Figure 10: Photographs of the valve spindle and seat ring surfaces after 1,000 hours [6].



Figure 11: Photographs of the valve spindle and seat ring surfaces after 9,100 hours [6].

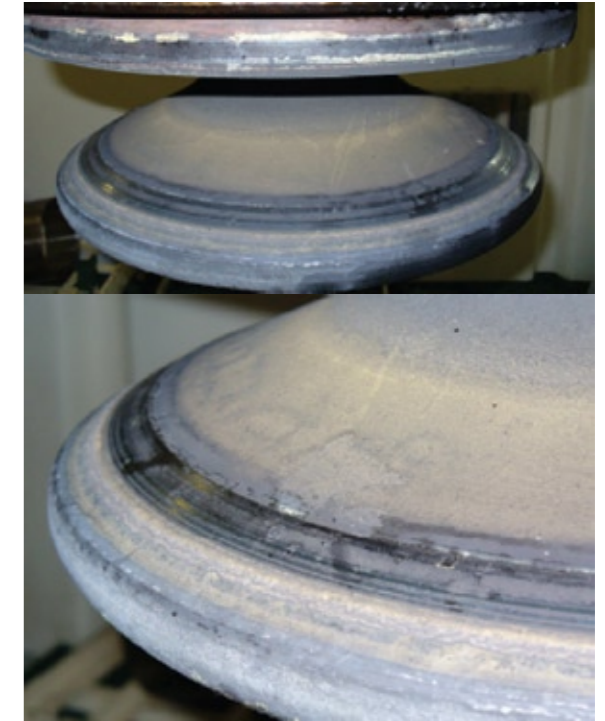

Figure 12: Photograph of the valve spindle and seat ring surfaces after 16,647 hours [6].



Figure 13: Photograph of valve spindle seat surfaces after 31,882 hours.



Figure 14: Photograph of valve spindle seat surfaces after 37,505 hours.



Figure 15: Photograph of the rotator gear and free-wheel after 31,882 hours.



Figure 16: Photograph of the outer helix gear inside the valvedrive after 31,882 hours.



Figure 17: Photograph of the inner helix gear after 31,882 hours.

DESIGN REFINEMENTS

Hydraulic oil drains and air spring chamber

Field tests on an MC90 engine have led to refinements of the Sentry Rotator design. Specifically, improvements have been made to the hydraulic oil drains and air-spring chamber. This refinement was done in 2006 and reported also in [6].

The need for increasing the capacity of the hydraulic oil drains was necessitated by the large oil flow requirement of large engine valve actuators. The addition of longitudinal grooves on the helical gear has increased the oil drain capacity to handle flow rates in excess of 500 l/hr.

The air-spring chamber design has also been modified. This was done in order to limit the maximum air pressure within the system and match the characteristic of the original air-spring, as shown in Figure 18 and Figure 19.

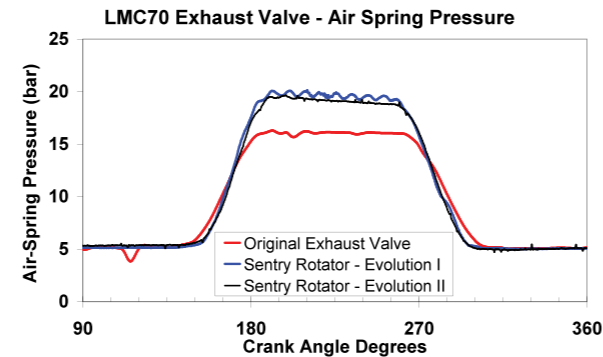

Figure 18: Comparison of the air-spring chamber pressure for original valve assembly (no rotator), initial rotator (Evolution I), and refined rotator design (Evolution II) [6].

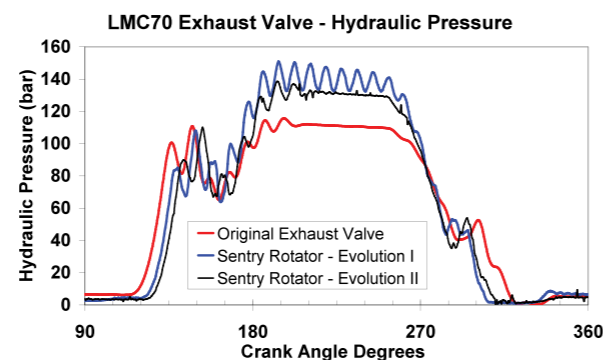

Figure 19: Comparison of the hydraulic drive pressure for original valve assembly (no rotator), initial rotator (Evolution I), and refined rotator design (Evolution II) [6].



Effect of seating pressure on the removal of glassy-deposits from the valve spindle seat

The mechanism of the glassy-deposits was discussed in the beginning of this paper (see also Figure 4, Table 1, and Figure 5). To remove these hard deposits during engine operation, the necessary and sufficient conditions are:

- Seating pressure of more than 400 MPa
- Rotation of the valve spindle during closing

On most of the 2- and 4-stroke engines the seating pressure of the exhaust valve spindles operate below 100 MPa, see also [7]. The geometry of the W-type bottom piece reaches seating pressures of 400 MPa or more. Similarly, after modifying the interference angle of the seat (changing the seat angle of the valve spindle or changing the seat angle of the bottom piece), the necessary seating pressure with a minimum of 400MPa can be achieved for exhaust valves with the common bottom piece geometries. To limit the valve spindle wear on the seat area, the seating pressure should not exceed 800 MPa.

Figure 5 shows the seat area of a valve spindle (W-type geometry of bottom piece) with removed glassy-deposits at the contact area. In the majority of cases, MWH has seen that vane-driven valve spindles do not rotate after the valve spindle seat initiates contact with the bottom piece during closing. With seating pressures above 400 MPa, the glassy-deposit layer is effectively destroyed in the seat contact area, but lacking rotation of the valve spindle seat against the bottom piece, the particles of the glassy-deposits are pressed into the valve spindle seat, forming dentmarks and the beginning of blow-byes.

To solve the newly observed problem with glassy-deposits, the MWH ReliaValve Evolution III was developed. This improved design combines the proven ReliaValve Evolution II with a new seat interference angle for higher seating pressure (more than 400 MPa). The end result is a very effective solution to combat the newly discovered and dangerous problem of glassy-deposits. These results can be seen in Figure 20, where the hard particles of the glassy-deposits do not create dentmarks during the closing process. Note that region "A" is the seat mating surface area that is both free of glassy-deposits and dents. Region "B" is the remainder of the seating area which, although covered by glassy-deposits, does not negatively influence the operation of the valve (i.e. does not create blow-byes).



Figure 20: Valve spindle seat with removed glassy-deposits (chamber type geometry of bottom piece with modified seat angle for higher seating pressure).



SUMMARY

An innovative and patented mechanical valve rotation mechanism has been developed for use in large 2-stroke diesel engines. This mechanical rotator (Sentry Rotator) can be incorporated into existing exhaust valve assemblies with minor additional modifications, and provides positive rotation of the valve spindle during the closing process. Application of the Sentry Rotator addresses the two main wear mechanisms in 2-stroke exhaust valves (adhesion and abrasive wear, and build-up of deposits and dent marks), thereby extending the service life of these components. An engine field test program has resulted in some refinements to the rotator design, and ultimately to a well proven product.

Based on the current operating conditions of ecospeed or low-steaming, some cases of a new type of wear, the so called "glassy-deposits" on the seat of valve spindles can also be eliminated by increasing seating pressure and grinding effect with the ReliaValve Evolution III.

Results obtained thus far demonstrate that a TBO of 30,000 hours, or more, are achieved for exhaust valve assemblies.

REFERENCES

- [1] Lampert, E., "Reducing Downtime for the 2-Stroke Engine," *MER Magazine*, November 2004, pp. 54-55, 2004.
- [2] Fellman, H., T. Gross and T. Ludwig, "Typical Wear Mechanism of 2-Stroke Exhaust Valves," Proceedings of the 2004 Marine Propulsion Conference. 2004.
- [3] Kvernes, I, P. Kofstad and M. Seiersten, "High temperature corrosion and protection of diesel engine exhaust valves", Central Institute for Industrial R, University of Oslo, D101, CIMAC 1981.
- [4] Umland, F and M. Ritzkopf, "Valve corrosion in diesel engines" *MTZ* Vol36, No.7/8, pp. 191-195 (July/August 1975).
- [5] Kingston-Jons, M.G., J.R. Thomas and A. S. Radcliff, "Review of operating experience with current valve materials" *Trans I MAR E (C)*, Vol. 102, Conference I (1990) pp15-28.
- [6] Fellmann, H and R. Stanglmaier, "Development of a Novel 2-Stroke Exhaust Valve with a Mechanical Rotator to Achieve Three-Year TBO'S", Paper 84, CIMAC Congress 2007, Vienna.
- [7] Yamada, T, H. Sekiguchi and M. Mizushima, "Development of ceramic exhaust valves", Nippon Kokan, CIMAC D82 ,1985.